

High pressure on foam!

■ Times are hard for the manufacturers of polyurethane foams. In 12 months, the cost of production has risen from 0.35 to 0.40 euros per kilo (for the most usual polyether and HR foams). There is an unbalance between the supply and the demand at world level, a lack of investment by the large chemical groups in a sector which considered not to be very profitable, and so on. The sector finds itself in a situation similar to that of steel. Nobody can therefore reasonably expect that the upward movement will cease during 2005. The consequence is inevitable, and so the manufacturers of polyurethane foams have no choice but to reflect the rising cost of chemical materials in the prices charged for their products. The consequences will be damaging for the whole of our sector, since foams are an essential component of many different forms of furniture, and of bedding and padded furnishings in particular.

20-20 Technologies introduced to the stock market

■ This giant of drawing and interior design software is now quoted on the Toronto stock exchange. The company is hoping that this infusion of capital will enable it to increase its already considerable rate of growth. 20-20 offers off-the-shelf solutions which include design, sale, the supply chain and the manufacturing processes relating to the furnishing industry. The 20-20 software is marketed in more than 90 countries, and is used by over 25,000 customers worldwide.

EUROCLIFAL News is prepared and published by Euroclifal European coordination and information centre for suppliers to the furnishing industry
www.euroclifal.net
Phone: + 33 1 40 21 26 72 ■ Fax: + 33 1 43 20 40 11
Postal address : BP 112 F-75663 Paris Cedex 14

The Euroclifal 2005 prizes reward the most notable innovations in our sector

The recent **Approfal** exhibition in Paris, which took place from 13 to 17 January 2005 in the Parc des Expositions at the Porte de Versailles, simultaneously with the International Furniture Exhibition (Salon International du Meuble), was the occasion, as it is every year, to award the **Euroclifal** Trophies. In the Materials category, the Adriano Ribera prize for innovation was awarded to the **Roxipan** company, while the prize for innovation in Hardware was awarded to the **Grass** company.

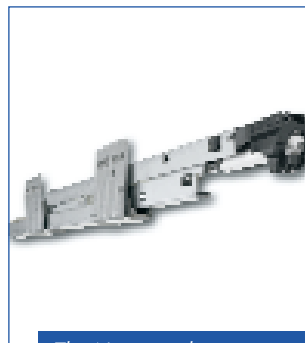

The Novapro drawer runner

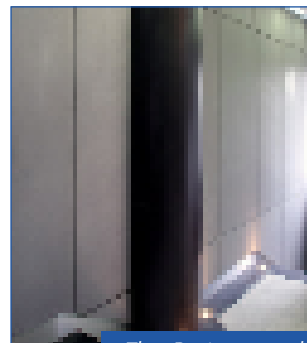

The Roxipan panels

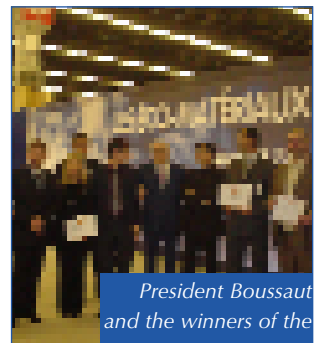

President Boussaut and the winners of the Euroclifal prizes

The prize for Hardware Innovation went to Grass

Grass was selected for the whole of its collection, which included useful and original solutions for both kitchen and storage application. However it is its new Novapro runner in particular, with Airmatic damper built directly into the runner, that awakened the enthusiasm of the jury for the Innovation prize. This damper enables drawers to be closed gently and noiselessly. A piston is operated as the drawer is closed. This creates a cushion of air in the pneumatic actuator, which absorbs the energy of the movement to begin with, and then allows it to release silently in a few moments. For its part, the prize for innovation in the Materials category was awarded to the **Roxipan** company for its wood-particle panels covered with a developed micro-concrete layer. Concrete decor, which represents a strong trend in contemporary interior decoration, has been lacking a product that is quick and easy to apply. The Roxipan dry panels were created just to fill this very gap. The Roxipan product is particularly innovative in nature, and is suitable for the building trade and the internal renovation of buildings. Its large dimensions (some 3 metres per panel) enable new or existing surfaces to be covered rapidly and simply. The jury also awarded a commendation for the plastic film developed by **Rivanos-F&I** (Seoul, Korea), which allows a variety of functions to be incorporated permanently - anti-bacterial, aromatic, absorption of bad odours and even temperature regulation. Commendations were also awarded to several computer companies, including **20-20 Technologies** (Chatou, France), **Missler Software** (Evry, France), and **Lectra** (Paris, France). Finally, the Jean Prévot prize for communication was awarded to **Timbo**, a French manufacturer of beds and bed bases, for the quality of the presentation dossier for its products.